

EDC Lesson 12: Transistor and FET Characteristics

Lesson-12: MOSFET (enhancement and depletion mode) Characteristics and Symbols

1. Metal Oxide Semiconductor Field Effect Transistor (MOSFET)

Types of FETs

The family of FETs may be divided into :

- Junction FET
- Depletion Mode MOSFET
- Enhancement Mode MOSFET

Remember JFET Definition

- JFET is a unipolar-transistor, which acts as a voltage controlled current device and is a device in which current at two electrodes is controlled by the action of an electric field at a reversed biased p-n junction.

MOSFET Definition

- MOSFET Field effect transistor is a unipolar-transistor, which acts as a voltage-controlled current device and is a device in which current at two electrodes drain and source is controlled by the action of an electric field at another electrode gate having in-between semiconductor and metal very a thin metal oxide layer .

-

n-channel depletion Metal-Oxide-Semiconductor FET (MOSFET)

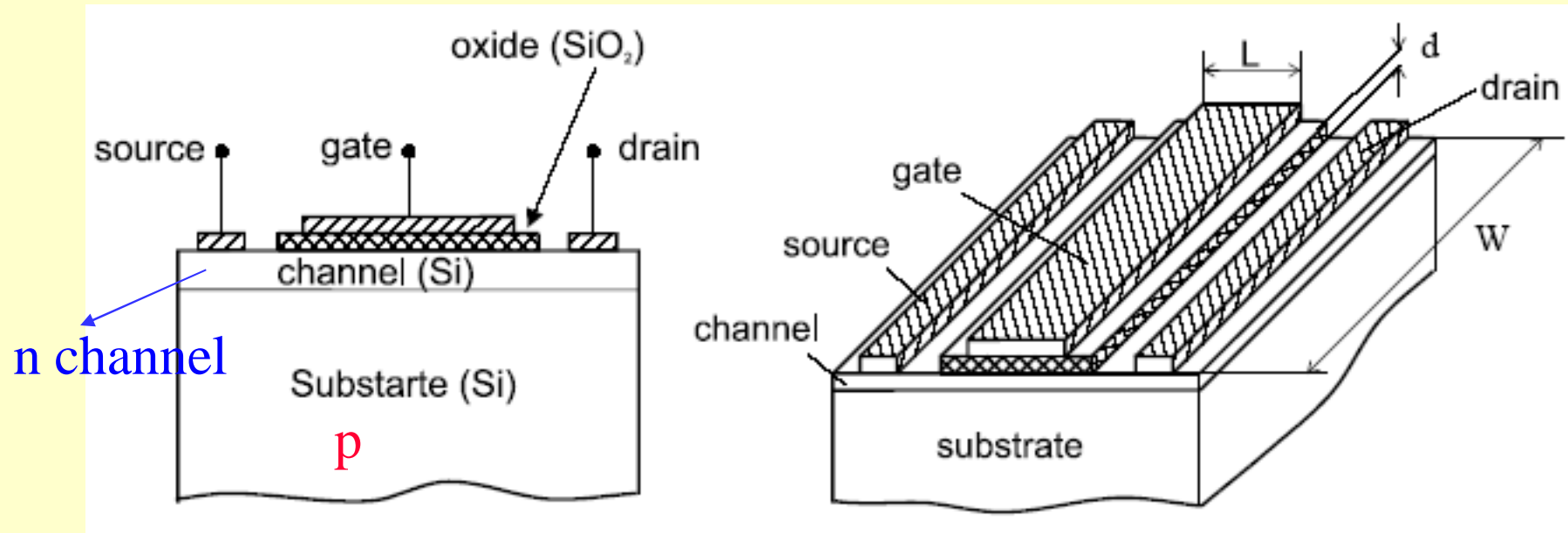

The gate-channel insulator is made out of dielectric (SiO_2), $\epsilon = 3.9$

p-channel depletion Metal-Oxide-Semiconductor FET (MOSFET)

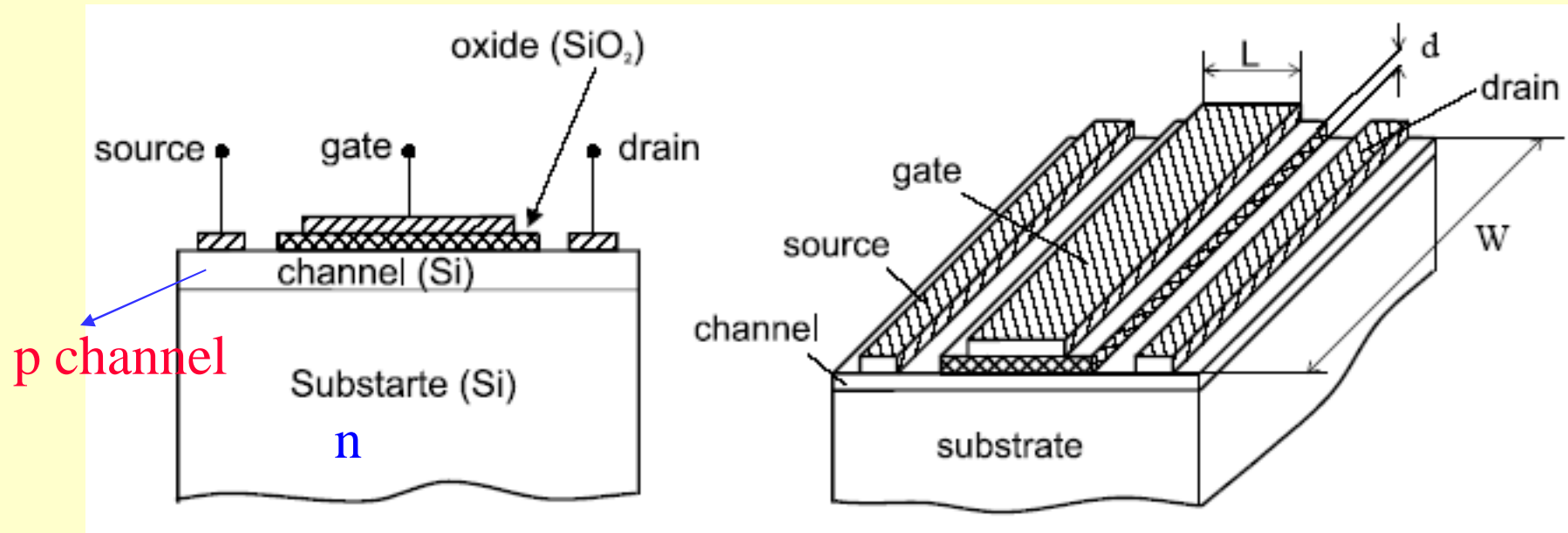

The gate-channel insulator is made out of dielectric (SiO_2), $\epsilon = 3.9$

Effect of Insulating SiO_2 (metal-oxide) layer

- MOSFET Very high input impedance due to SiO_2 layer compared to even reverse biased p-n junction depletion region input impedance in JFET

n-channel depletion region

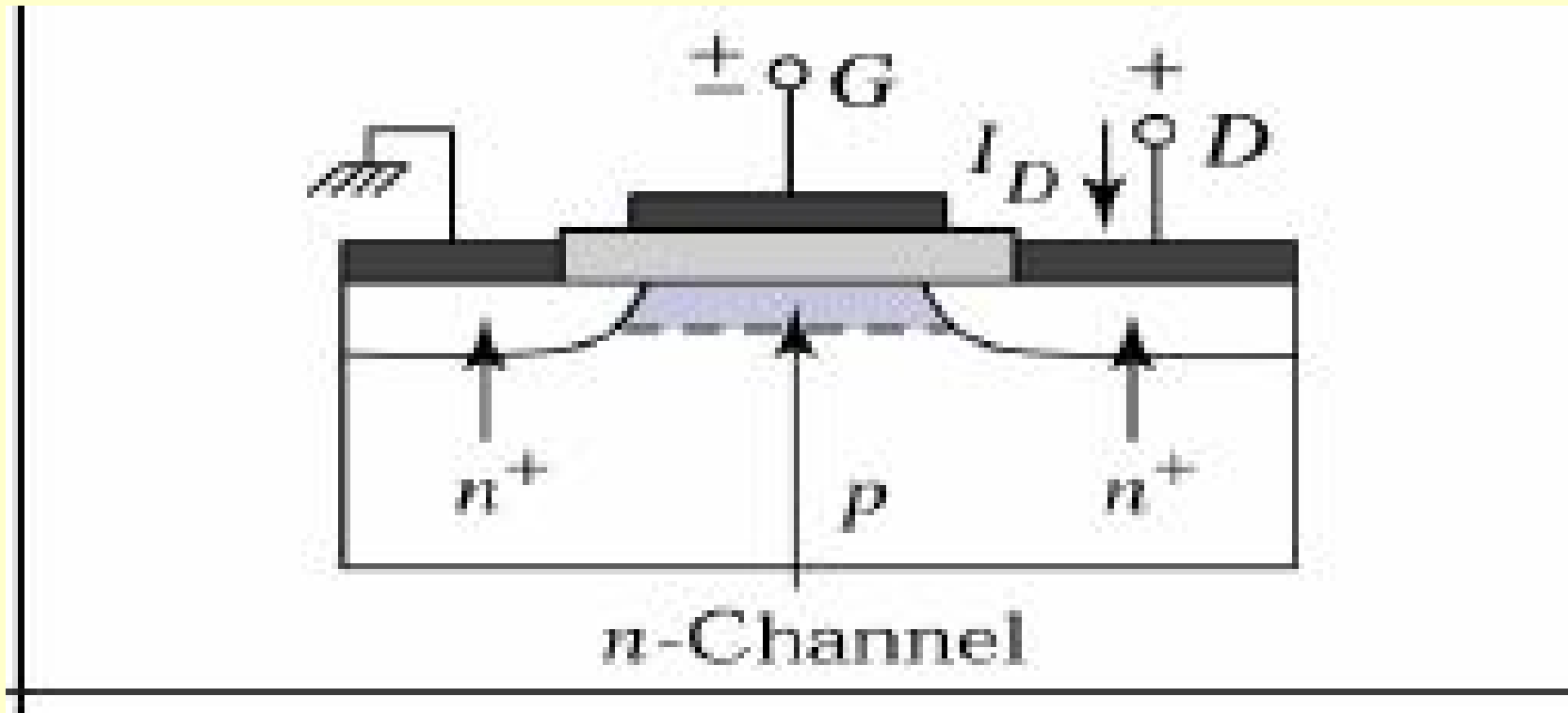

n-channel depletion region (normally ON)

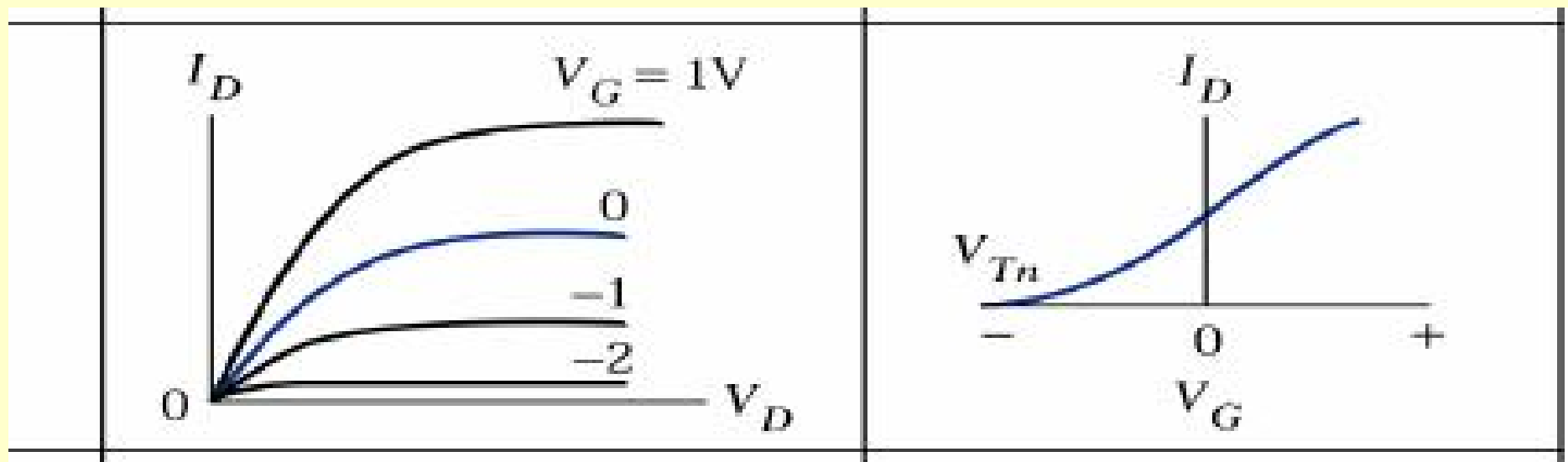

Transfer Characteristics of n-channel depletion region MOSFET

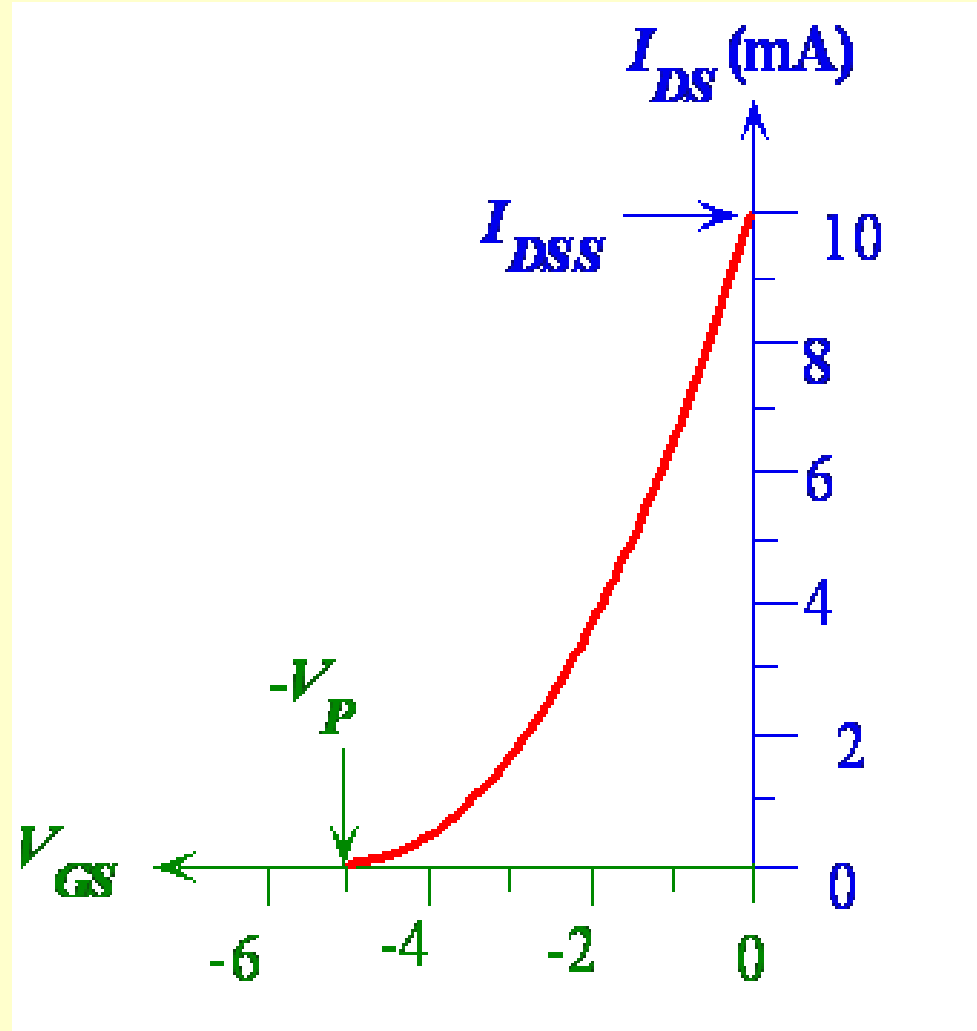

- There is a convenient relationship between I_{DS} and V_{GS} .
- Beyond pinch-off

$$I_{DS} = I_{DSS} \left[1 - \left(\frac{V_{GS}}{V_{GS(off)}} \right) \right]^2$$

- Where I_{DSS} is drain current when $V_{GS} = 0$ and $V_{GS(off)}$ is defined as $-V_P$, that is gate-source voltage that just pinches off the channel.
- The pinch off voltage V_P here is a +ve quantity because it was introduced through $V_{DS(sat)}$.
- $V_{GS(off)}$ however is negative, $-V_P$.

p-channel depletion MOSFET

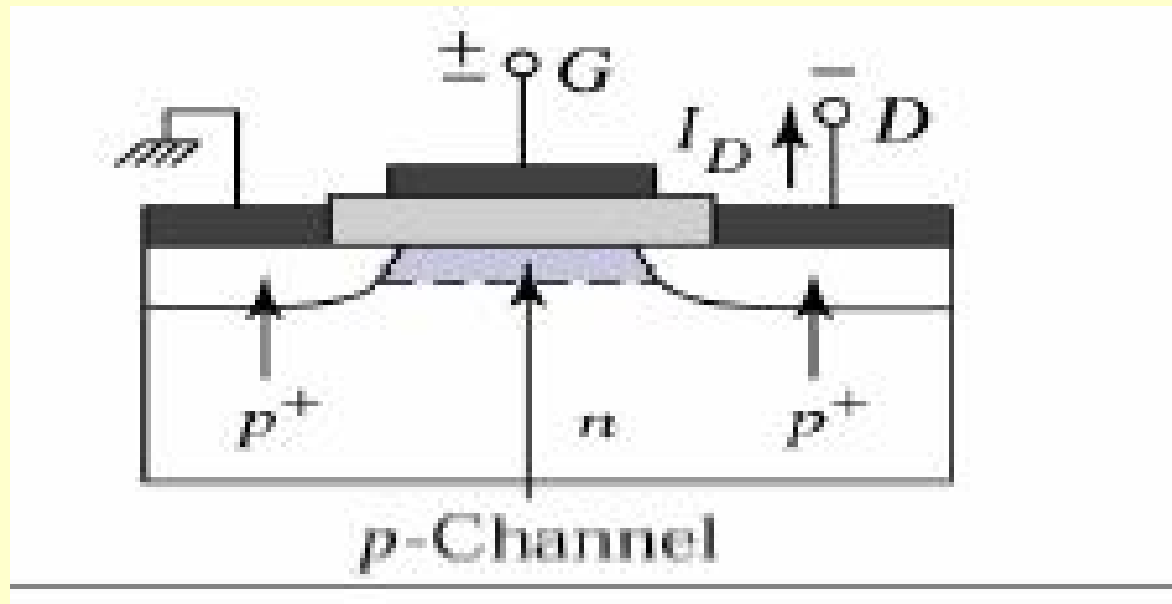

p-channel depletion MOSFET (Normally ON at $V_{GS} = 0$)

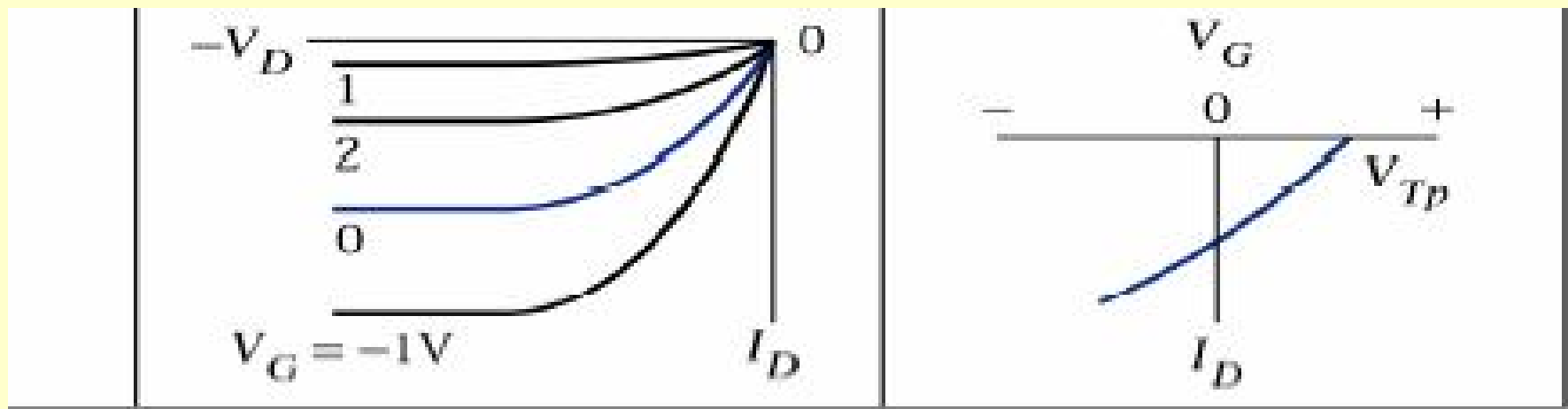

2. Enhancement Mode MOSFETS

n-channel enhancement mode MOSFET

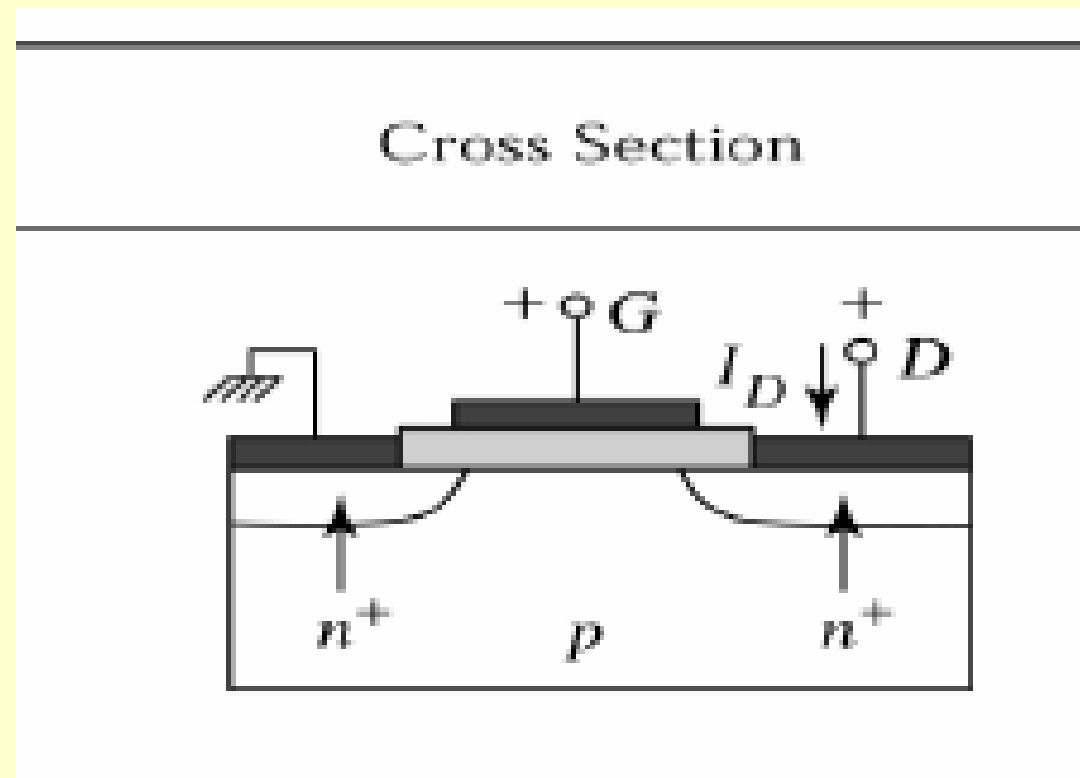

n-channel enhancement mode Normally Off

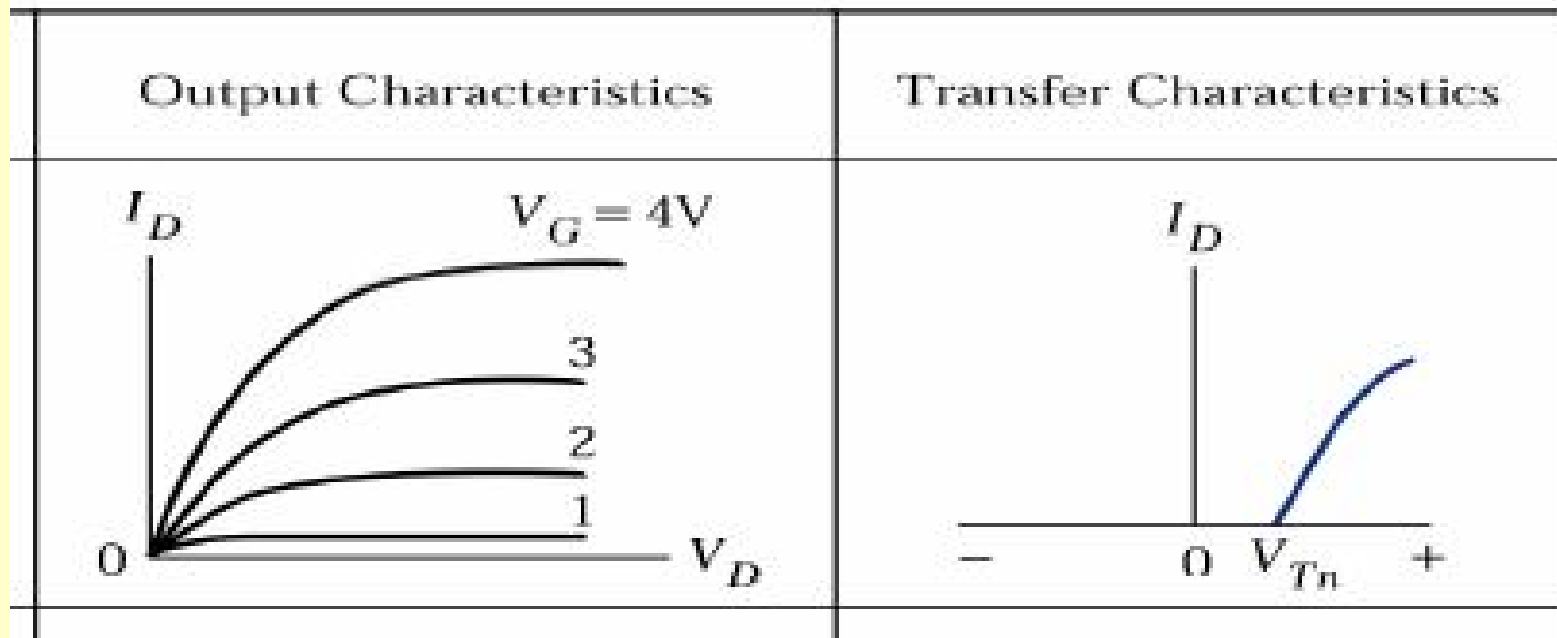

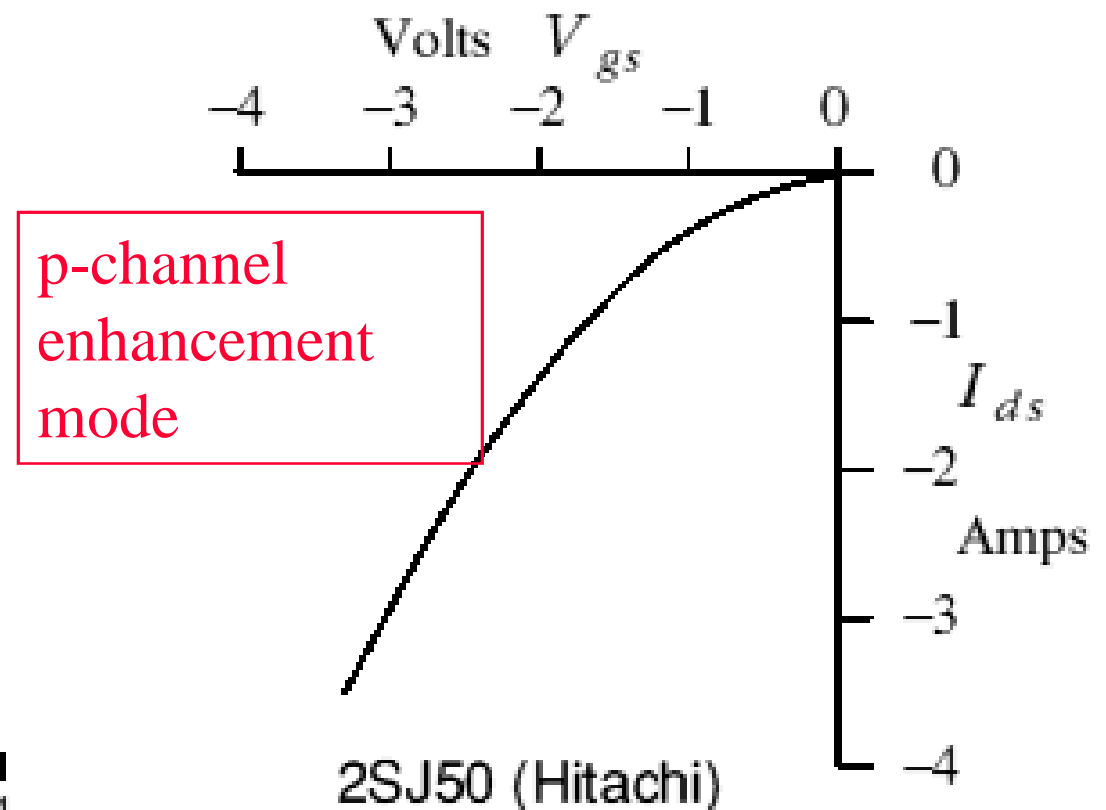
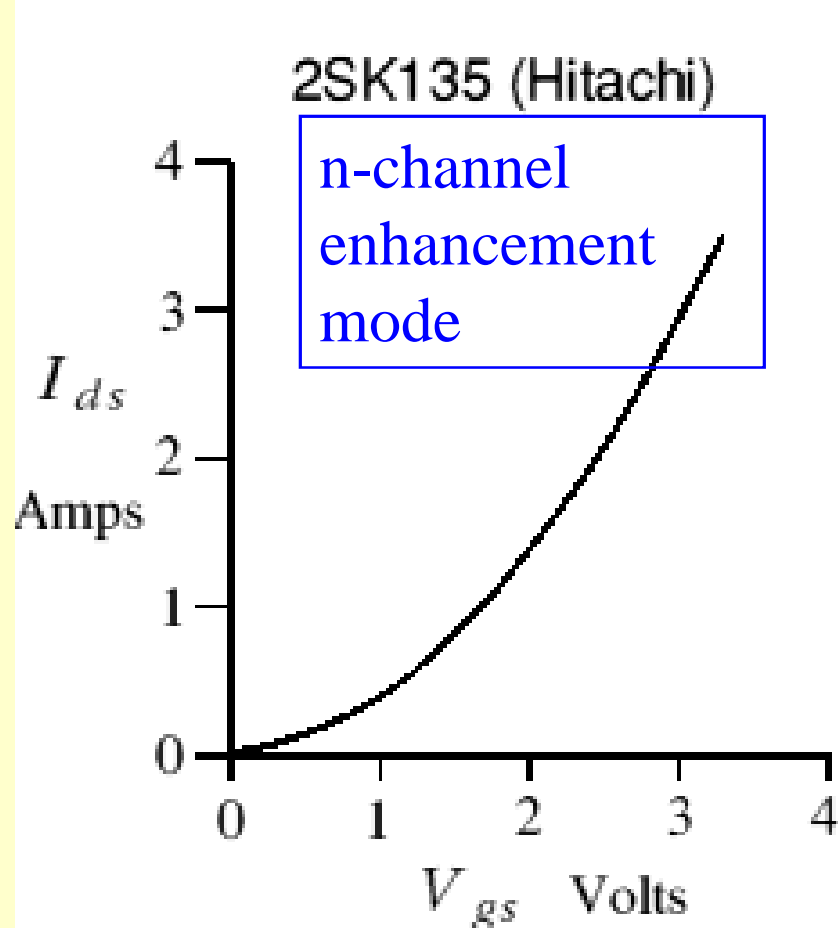

- Note that with a n-channel device we apply a +ve gate voltage to allow source-drain current, with a p-channel device we apply a -ve gate voltage.

p-channel enhancement MOSFET

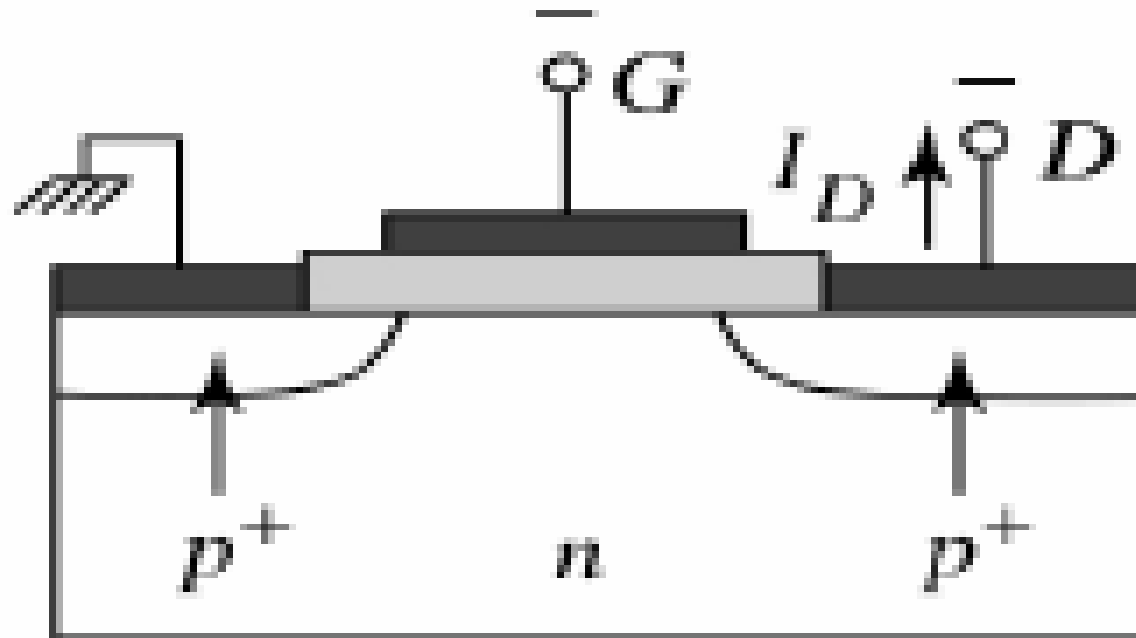

p-channel enhancement MOSFET (normally OFF)

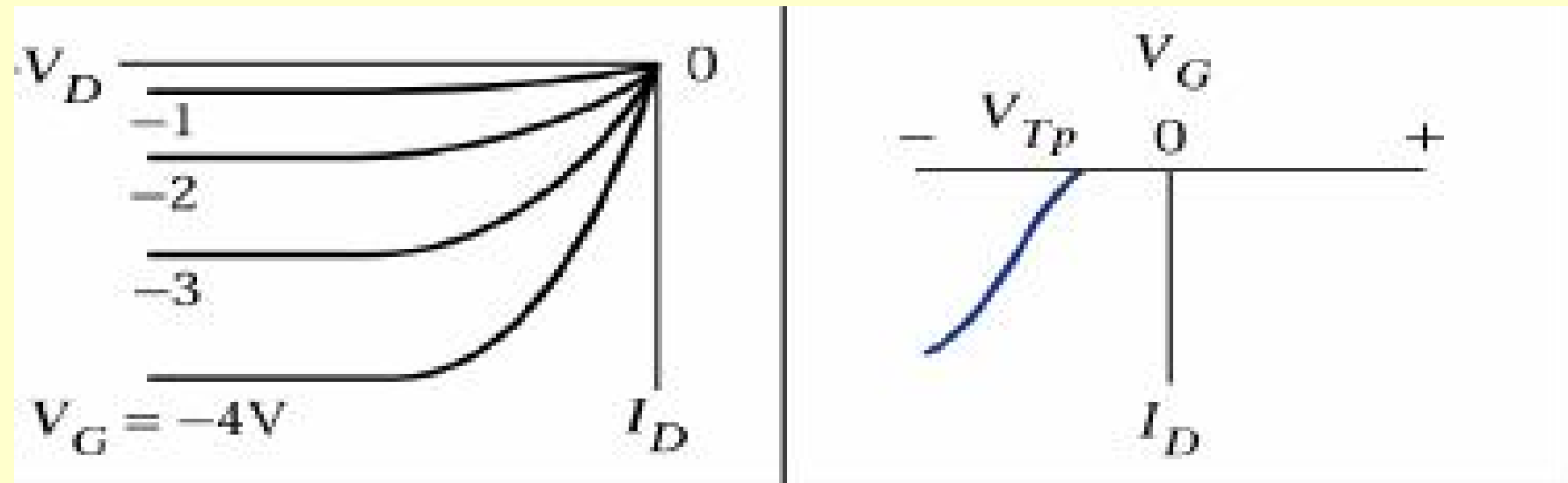

3. Enhancement Mode MOSFETS in detail

Basic MOSFET (n-channel) Enhancement mode

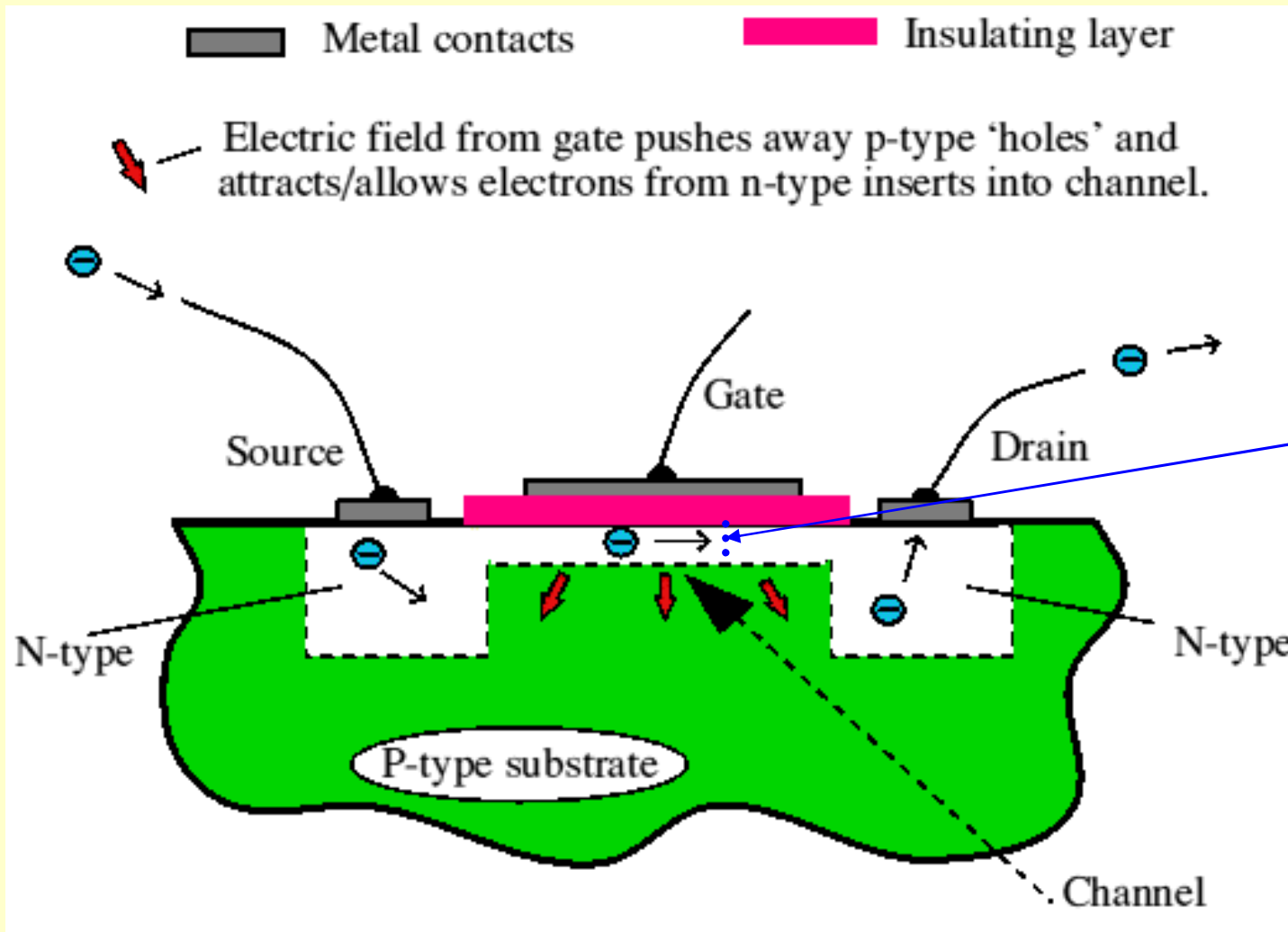

When $V_{GS} = 0$, the n-channel is very thin and channel width enhances with $+ V_{GS}$

Channel width enhancement with $+V_{GS}$

- The gate electrode is placed on top of a very thin insulating layer.
- There are a pair of small n-type regions just under the drain & source electrodes.
- If apply a +ve voltage to gate, will push away the 'holes' inside the p-type substrate and attracts the moveable electrons in the n-type regions under the source & drain electrodes.

Enhancement mode MOSFET

- Increasing the +ve gate voltage pushes the p-type holes further away and enlarges the thickness of the created channel.
- As a result increases the amount of current which can go from source to drain — this is why this kind of transistor is called an *enhancement mode* MOSFET.

Subthreshold region in n-channel enhancement mode

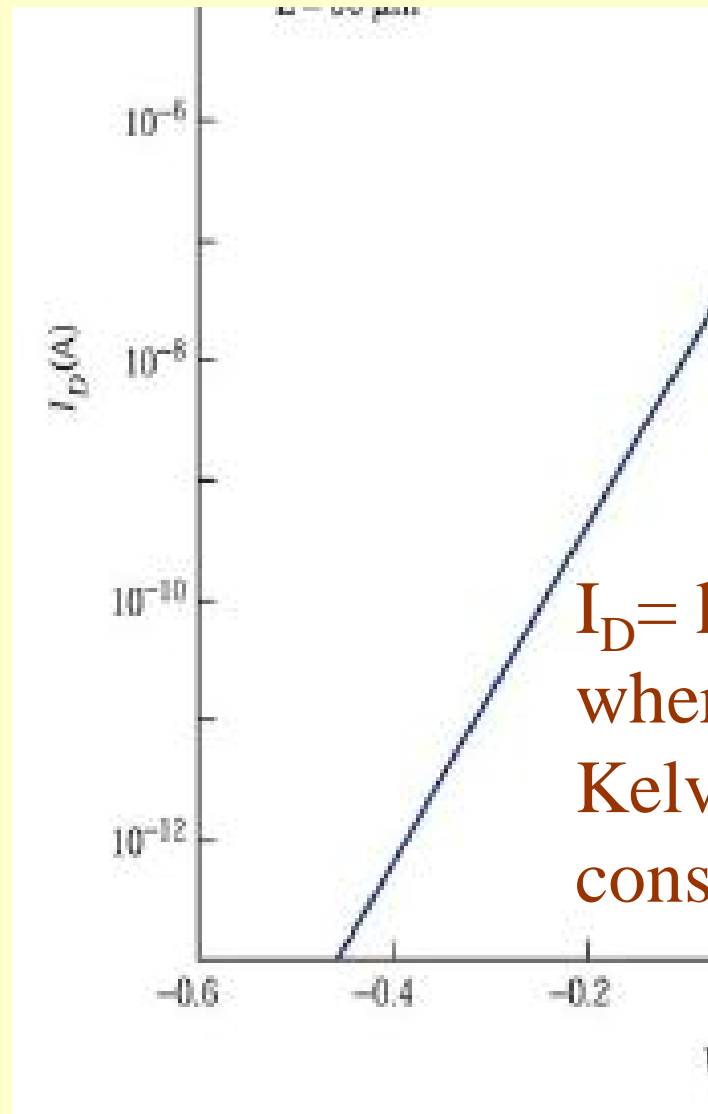

$I_D = k \exp(qV_{GS}/k_B T)$
where T temperature in Kelvin, k_B is Boltzmann constant

Subthreshold region in n-channel enhancement mode

Ideal case: $I_D = 0$ when $V_G < V_T$
 Real device – subthreshold current:

$$I_D = k (V_{GS} - V_T)^2$$

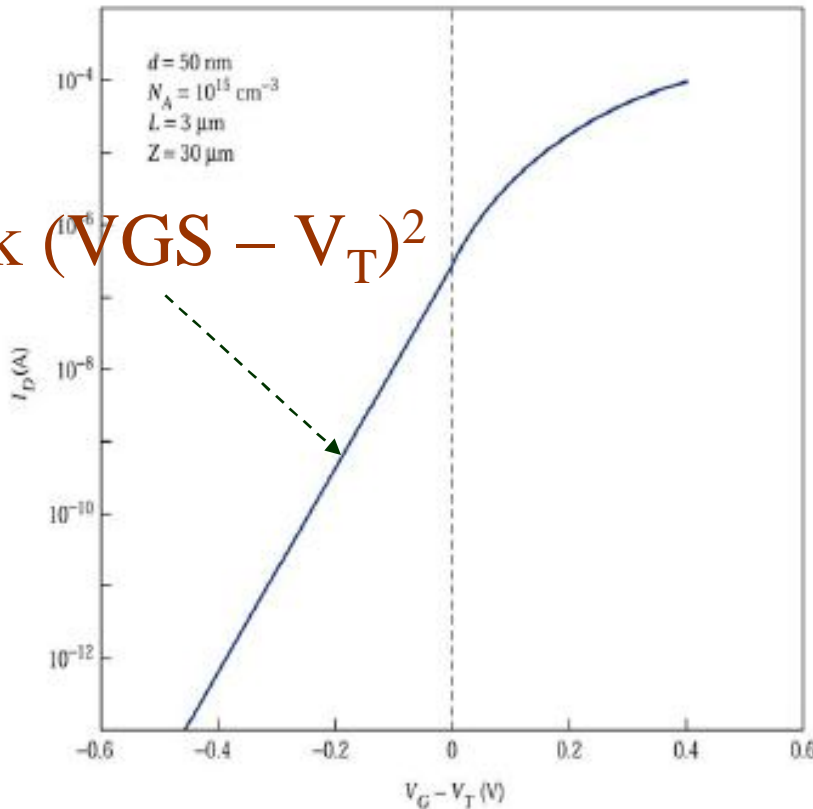

Origin?

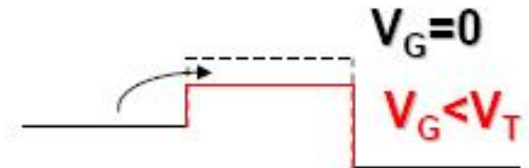

Diffusion current !:

$$I_D(sub) \propto \exp\left(\frac{qV_G}{kT}\right)$$

Important parameter – subthreshold swing S :

$$S = \left[\frac{\partial(\log I_D)}{\partial V_G} \right]^{-1}$$

S should be as small as possible: 70 -100 mV/decade

Small $V_T \rightarrow$ High subthreshold (leakage) current, high power losses
 High $V_T \rightarrow$ Low drive current
 Historically - $V_T \approx 0.7 \text{ V}$

Above Threshold – ON state

$$I_D = k (V_{GS} - V_T)^2 =$$
$$0.278 \times (V_{GS} - V_T)^2 \text{ mA}$$

If I_D (on) = 10 mA and

$V_{GS} = 8 \text{ V}$, then k
 $= 10 \text{ mA} / (8 \text{ V} - 2 \text{ V})^2 = 0.278$
 mA/V^2

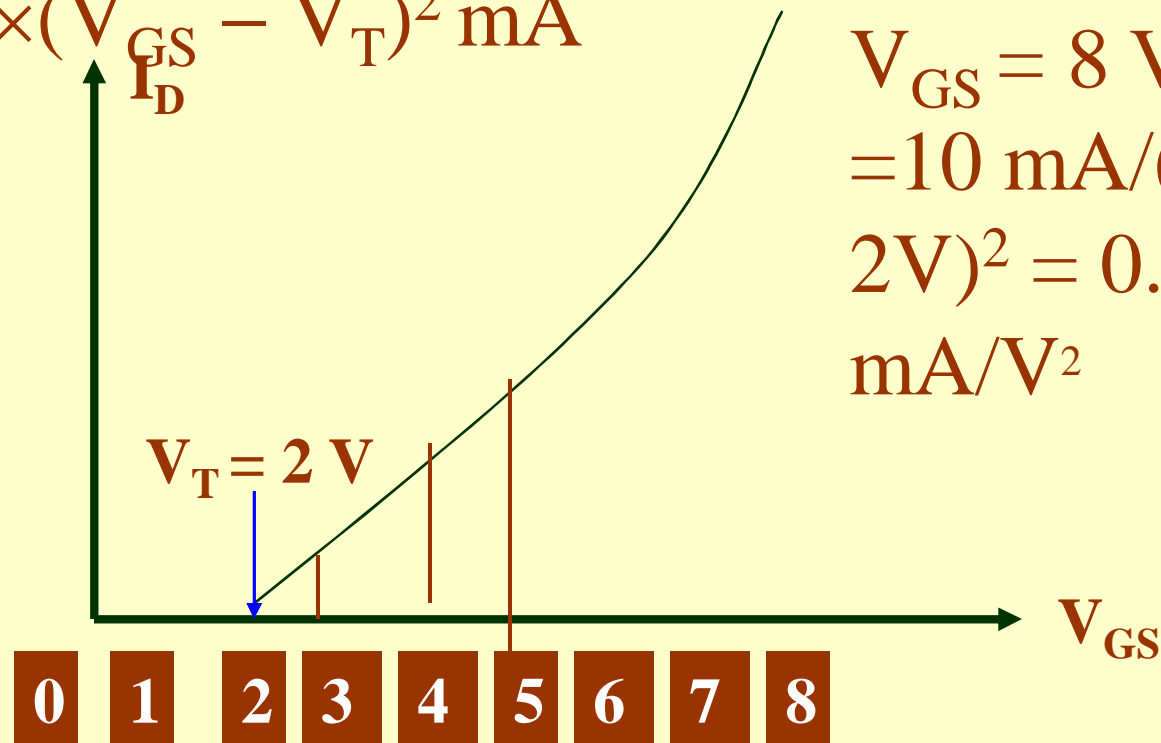

Above Threshold – ON state

$$V_T = 2 \text{ V}$$

$$I_D = k (V_{GS} - V_T)^2$$

If I_D (on) = 10 mA and

$$V_{GS} = 8 \text{ V, then } k = 10 \text{ mA} / (8 \text{ V} - 2 \text{ V})^2 = 0.278 \text{ mA/V}^2$$

$$I_D = k (V_{GS} - V_T)^2 = 0.278 \times (V_{GS} - V_T)^2 \text{ mA}$$

Ideal Output Characteristics of MOSFET

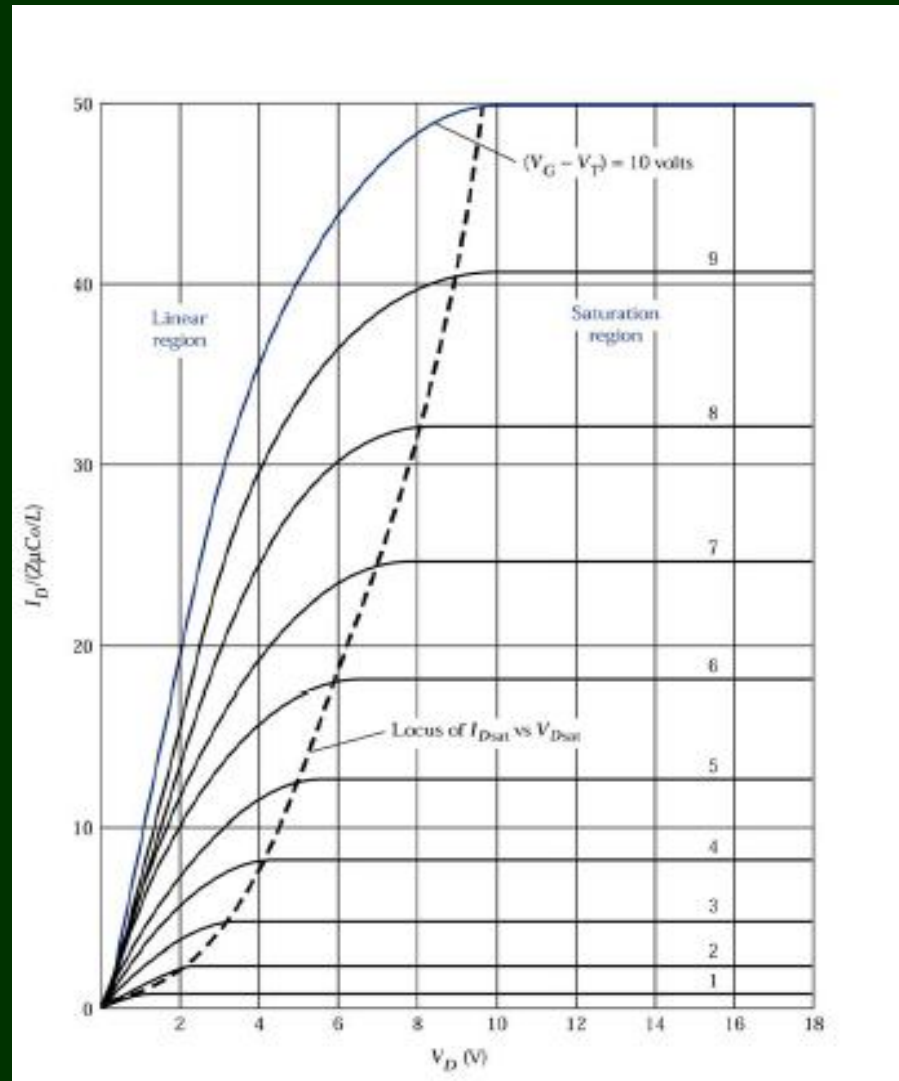

Ideal Output linear region before saturation Characteristics of MOSFET

$$I_D = f(V_D), V_G = \text{const:}$$

1) Small V_D – linear region

$$I_D = \frac{z\mu_n C_i}{L} (V_G - V_T) V_D$$

$$g = \frac{\partial I_D}{\partial V_D} = \frac{z\mu_n C_i}{L} (V_G - V_T)$$

↖ Channel conductance g is determined by V_G

Ideal Output Saturation formula of enhancement mode MOSFET

2) Saturation:

$V_D(\text{sat}) \rightarrow Q_n(L) = 0$ - pinch-off near the drain

$$V_D(\text{sat}) \approx V_G - V_T$$

$$I_D(\text{sat}) = \frac{z\mu_n C_i}{2L} (V_G - V_T)^2$$

$$g = 0$$

☛ I_D is determined by V_G , does not depend on V_D

changing $z \rightarrow$ Change in the current capacity

Transfer Characteristics in above threshold region and saturation region in n-channel enhancement mode

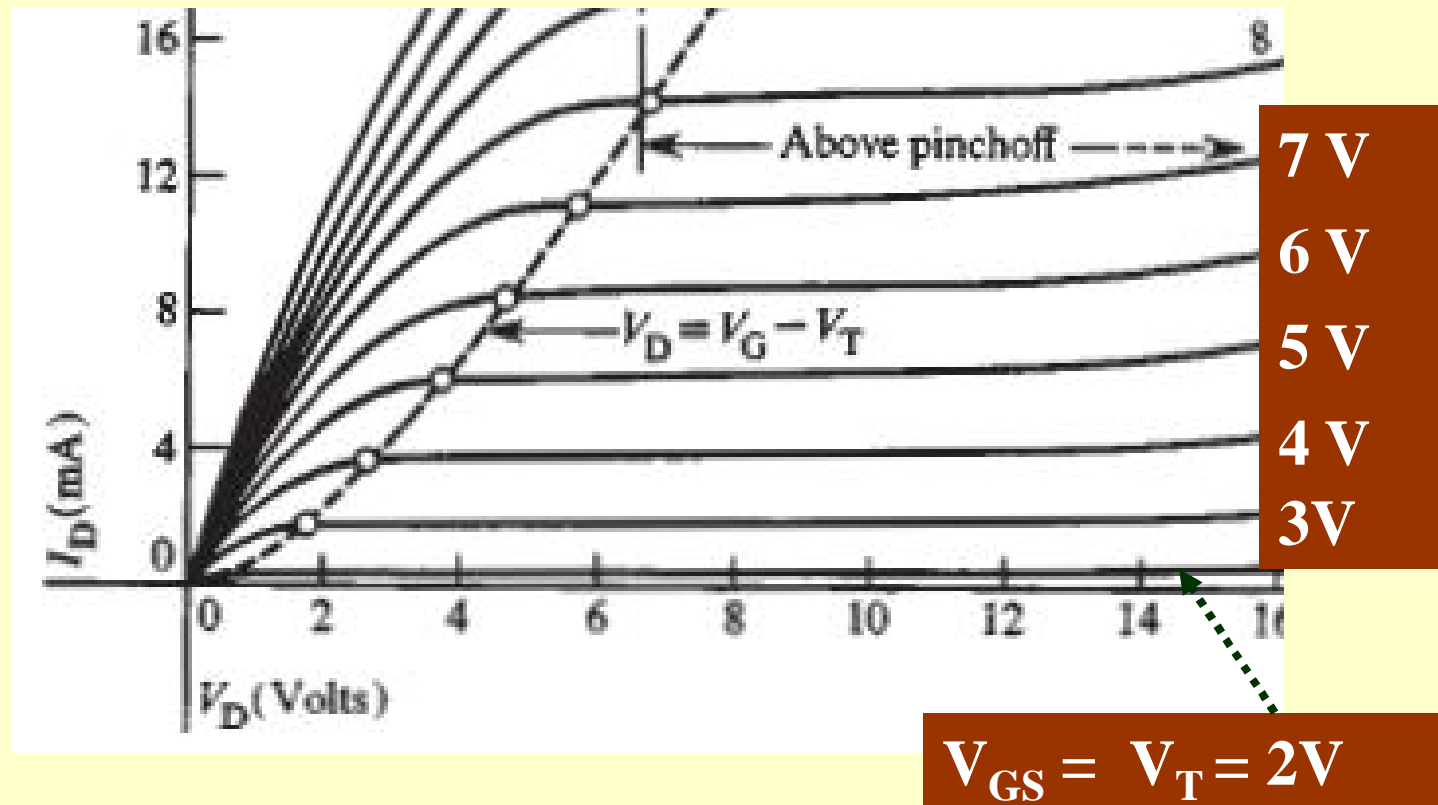

Transfer Characteristics in Subthreshold region and saturation region in n-channel enhancement mode

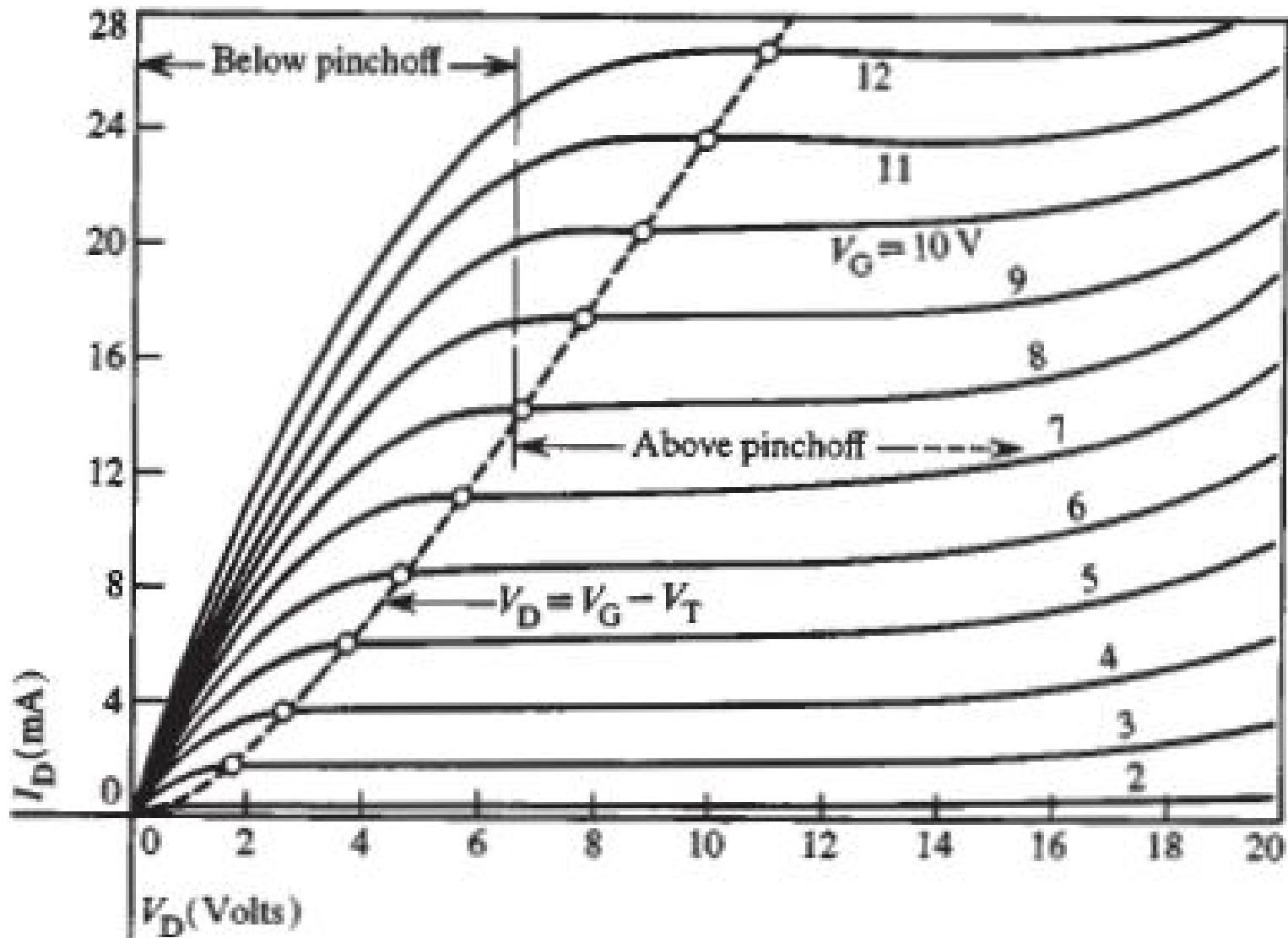

4. Symbols of depletion and Enhancement Mode MOSFETS

Symbol of depletion mode MOSFET

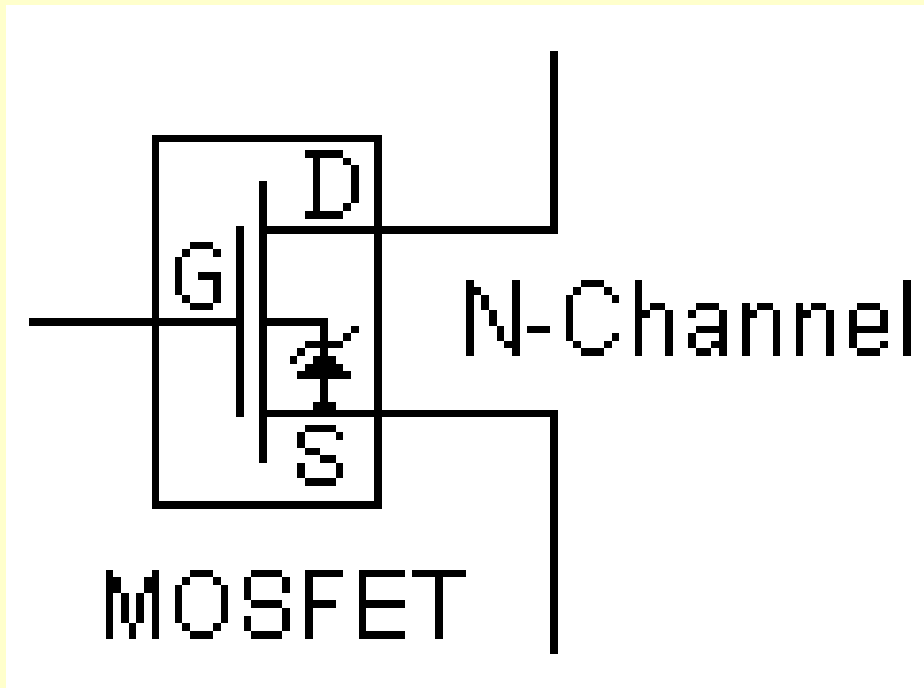

n-channel Depletion
Mode MOSFET

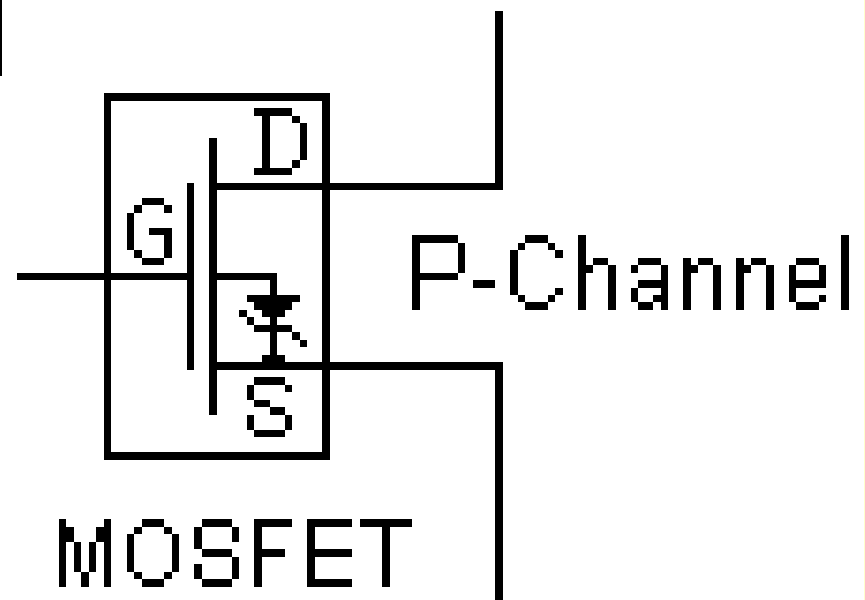

p-channel Depletion
Mode MOSFET

Symbol of enhancement mode of MOSFET

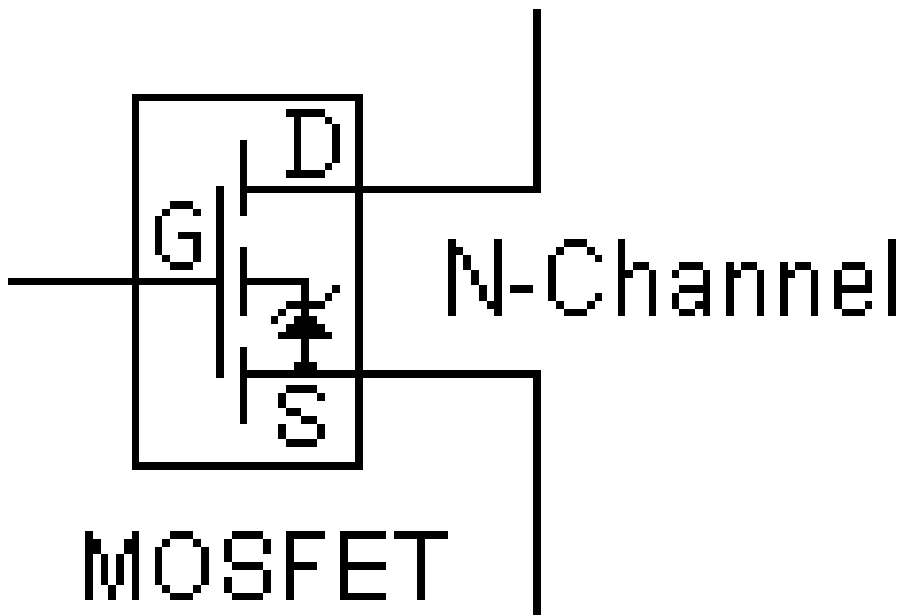

**n-channel
Enhancement Mode
MOSFET**

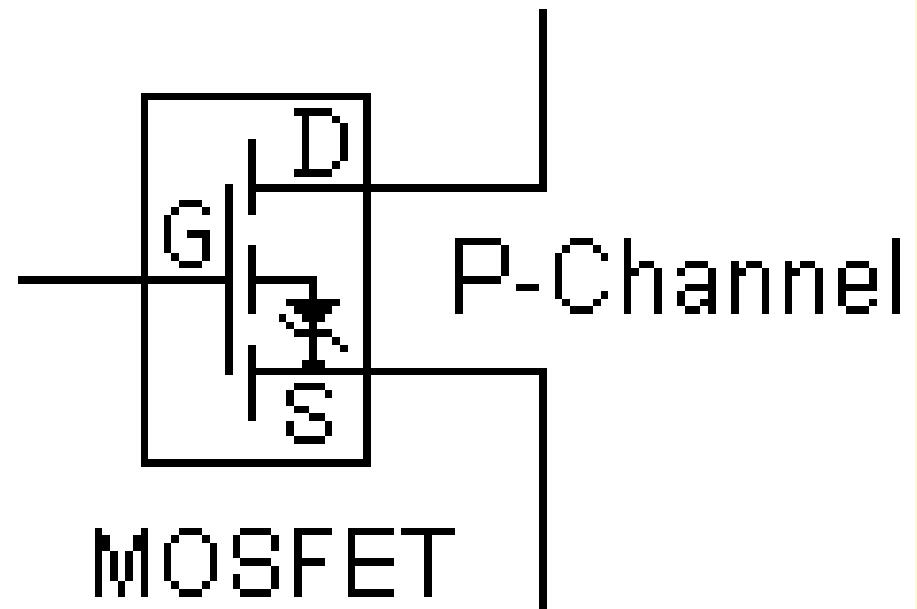

**p=channel Enhancement Mode
MOSFET**

Summary

We learnt

- Definitions of MOSFET
- n-channel and p-channel Depletion MOSFET normally ON, Pinch off on – VGS in n-MOSFET and + VGS in p-MOSFET
- n-channel and p-channel enhancement MOSFET normally OFF, below Threshold and above V_T on + VGS in n-MOSFET and - VGS in p-MOSFET

End of Lesson 12